



CAR VISION COLOUR CAMERA

MODEL

C-4020

INSTALLATION MANUAL

This is a heavy-duty camera that allows the driver to view the blind spot and functions as a supplement to the rearview mirrors on trucks, buses and special vehicles. Use together with the monitor (CM-7210, CM-7220, CM-7230, CM-6000) or power adapter (P-0400) sold separately.

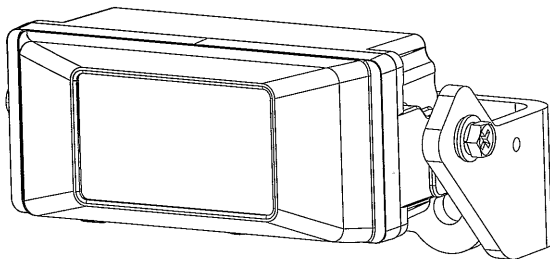

Please read this manual carefully before attempting to install and operate this equipment.

(Present this manual to the customer.)

U871Z288001A



SM-Y8440A

©2015 MITSUBISHI ELECTRIC CORPORATION ALL RIGHT RESERVED







Mar. 2015
MADE IN JAPAN



Please follow it for security by all means

- The meaning of "a figure sign" used in this manual is as follows.

	Prohibition		Keep instructions
	Don't take apart		

- ● Please read this column and use it safely before you use.
- Please be sure to follow matters that require attention shown here because the important contents about safety are written.
- Please keep this in the place where the user can read anytime after you read.

 <h2>Warning</h2>		When you use in a wrong way, contents that there is possibility of death or serious injury.	
If a trouble happens, turn off the main switch of a vehicle.  <p>Don't use a monitor in an abnormal state where no image is displayed or smoke, unusual noise or odor comes out of a monitor. It can cause a fire. In such a case, stop driving immediately and turn off the main switch of a vehicle. After you check that smoke has not appeared, please ask your dealer for repair.</p>	Don't damage or rework a cable.  <p>If you place a heavy object on a cable or bring it close to a heater, it is damaged. If you use a damaged cable, it can cause a fire or an electric shock. If you rework, twist or pull forcibly a cable, it can cause a fire or an electric shock. When a cable is damaged, please ask your dealer immediately.</p>		
Don't put a monitor in an unstable place.  <p>Don't put a monitor in an unstable place such as in a wobbly stand or a sloping place. Please install it in a stable place, otherwise it may drop or topple over, causing an injury. Please ask your dealer for installation.</p>	Don't operate a monitor while driving.  <p>Please operate the front switch of a monitor when a vehicle is stopping absolutely.</p>		
Don't put an alien substance.  <p>If a metal or inflammables enters a monitor, it can cause a fire. In such a case, you stop driving, turn off the main switch of a vehicle, please ask your dealer.</p>	Don't take apart or remodel a monitor.  <p>If you take apart a monitor and touch the parts inside, it can cause a fire or an electric shock. Please ask your dealer for internal check, adjustment or repair.</p>		

 <h2>Caution</h2>		When you do the wrong handling, this is a thing with the possibility that the damage occurs to an injury or a house / household effects.	
When cryoprotectant, salt water or seawater stuck, wash it.  <p>A camera is easy to become rust when neglect washing and it is flooded and a picture is not reflected.</p>	Please clean of camera front glass.  <p>A picture is hard to come to consider that front glass of a camera is stained. When it is stained, please clean it immediately.</p>		

<h2>Request</h2>	
Please carry carefully. Please handle with care because a minitor is fragile.	Please handle a cable carefully. If you place a heavy object on a cable or bring it close to a heater, a cable is damaged. In such a case, it can cause a trouble. When a cable is damaged, please ask your dealer immediately.

Caution in installation

Warning

Don't cut coating of a power supply wire and don't use a power supply wire as another power supply.

It exceeds current capacity of a wire and it can cause a fire or an electric shock.



Caution

Don't sandwich a cable in the moving part that vehicle body, screw or seat rail.

It can cause an accident, a fire or an electric shock by disconnection or short-circuit.



When you install a camera, a camera must not be beyond an outline of a vehicle.

A camera touches walkers and can cause an accident.



When you use the screw of a vehicle, install surely as not to loosen the screw.

It can cause an accident or a trouble.



Please insulate a camera and the vehicle body.

The insulation is need with a camera and the vehicle body. Please do not exclude insulation bush attached to a fitting.



Caution in use

Caution

Check mirror image (Same as back mirror) when you use for check rear view.

If you mistake setting, mistake check of right and left, it can cause an accident.



When you open a hole on the vehicle body and install a monitor or wire a cord, seal up a gap of the opened hole and a gap with a cord with silicon glue.

Exhaust gas or water invade in the room from a gap, it can cause an accident.



After wiring a cord, fix it by a clamp and an insulating tape.

If a cord comes in contact with a vehicle parts, it wears out and short-circuit, it can cause an accident or a fire.



When you open a hole on the vehicle body and wire a cord, use an insulation-related grommet.

By contact with an opening and a cord, it wears out and short-circuit, it can cause an accident or a fire.



Use an attached part according to the appointment by all means.

If you use a part except appointment, damages parts inside a monitor, can't fix surely, comes off, it can cause an accident or a trouble.



Do regular connection.

If you mistake connection, it can cause an accident or a fire.



When snow or ice stuck, please use it after having dissolved it.

Don't use commercially available de-icers. These may damage the camera.



1. CONFIGURATION

(1) Camera	1
(2) Accessories	
① Installation fitting (with insulator bushing)	1
② M5×20 sems hexagonal bolt	3 (Vehicle side)
③ M4×12 sems hexagonal bolt	2 (Camera side)
④ M5 Nut	3 (Vehicle side)
⑤ M5 Flat washer	3 (Vehicle side)
⑥ M3×6 Binding screw	1 (Camera side)
⑦ Cable clamp	1 (Camera side)
(3).INSTALLATION MANUAL(This book)	1

2. NOTES ON INSTALLATION

- (1) Attach the connector protruding from the camera securely in compliance with the cable installation instructions.
- (2) Make sure the water pressure is within 14.7MPa when washing the camera with high pressure washing equipment.
- (3) Flickering may appear on the screen under discharge lamp (fluorescent,mercury lamps,etc.) however this does not indicate a malfunction.
- (4) The installer shall enter the date the job was performed along with the name of the company and supervisor.
- (5) If the vehicle is to be painted, make sure it is done prior to camera and cable installation and wiring.

If you should decide to paint the camera in an installed state, make sure no paint gets on the accessory rubber or cables.

3. Tools

- Drill (for hole dia.6mm)
- Phillips screwdriver (No.2)
- Open ended spanners (No.7,8)
- Glue Cemedine super X No. 8008
- Megger (insulation resistance tester)

4. BASIC WIRING DIAGRAM

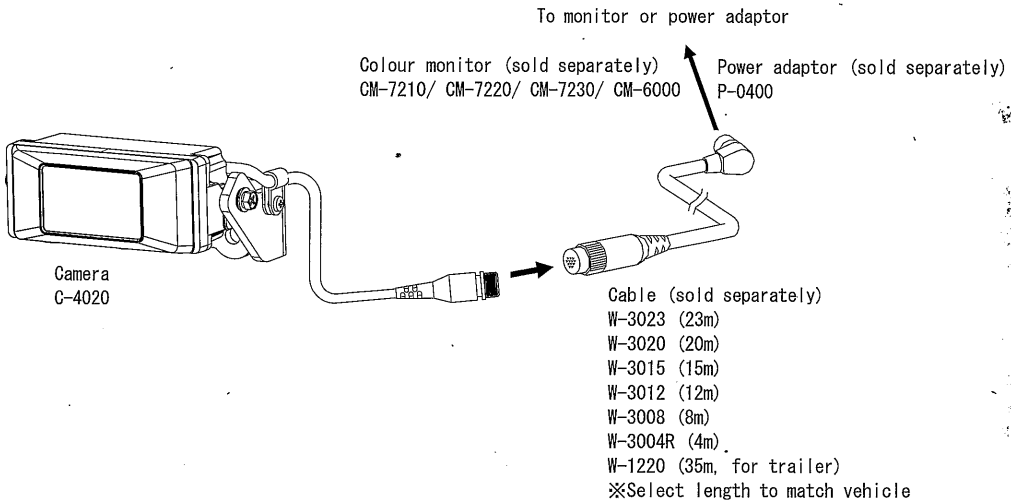

5. INSTALLATION

(1) Installing the installation fitting

- ① Check if the installation position is sufficiently strong and provide support at any weak points.

*Refer to the installation holes for drilling holes.

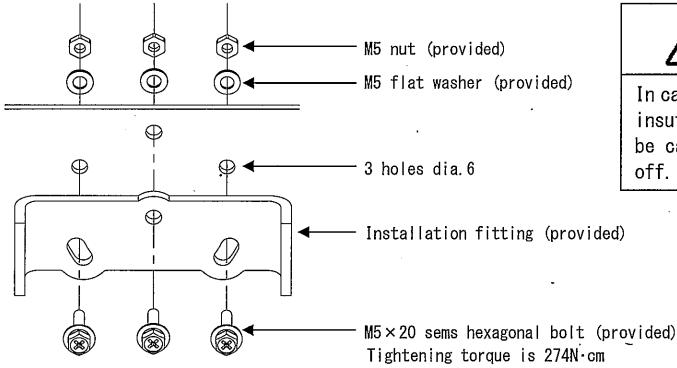

⚠ Caution

In case strength possesses an insufficient point, please be careful for fear of fall off.

Installation holes

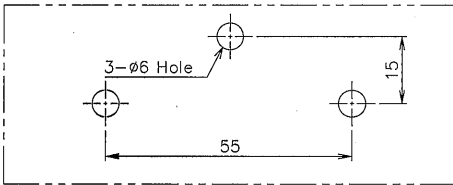

- ↑ Arrow direction
- EX1: Perpendicular installation : upside
- EX2: Perpendicular installation : downside
- EX3: Horizontal installation : frontside

*Waterproof locations such as installation holes to prevent leaks.

Glue of waterproofing recommends Cemedine super X No. 8008.

- ② Select and installation position from the examples below.

SAMPLE INSTALLATIONS

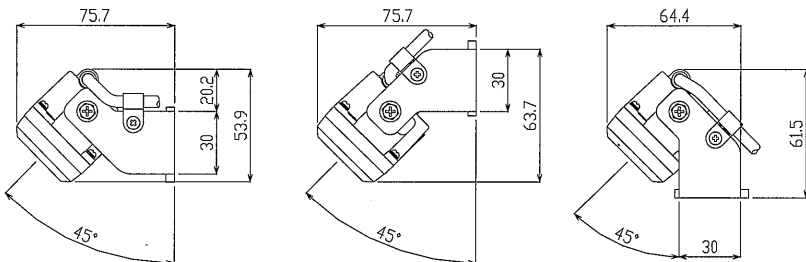

EX1: Perpendicular installation EX2: Perpendicular installation EX3: Horizontal installation

(2) Install the Camera

- ① Use the two M4×12 screws to affix the camera unit. Use one M3×6 screw to temporarily attach the cable clamp and cable.

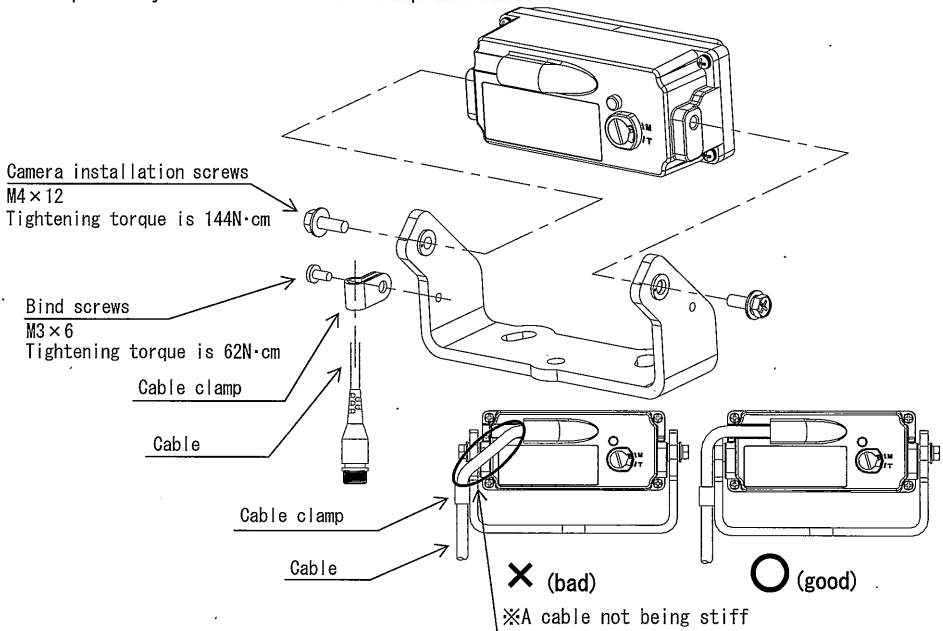

- ② Insulation is provided for the camera and its installation hardware so make a megger tester check of insulation prior to connecting the cable.

※ Insulation confirmation method

Please measure it with mega meters between a camera installation screw and fitting fixation bolts and confirm more than 10MΩ.

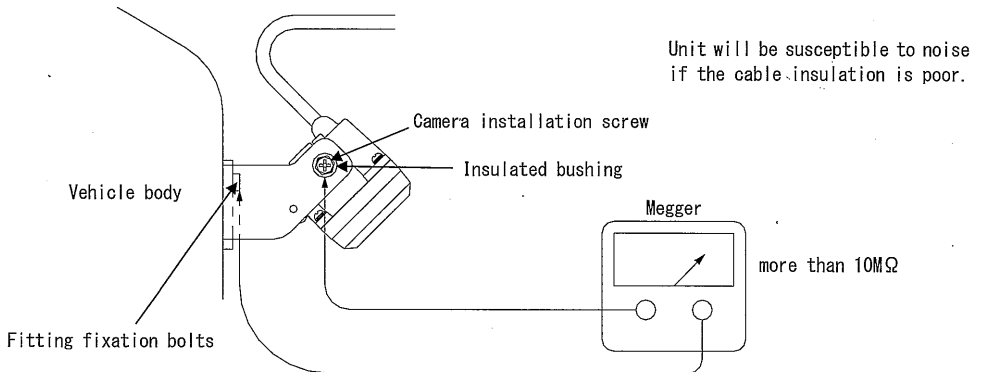

(3) Cable Connection

For details refer to the installation manual supplied with the cable and follow its instructions during installation.

PRECAUTIONS ON INSTALLATION

- ① During layout of the cable make sure not to place in proximity to antennas susceptible to noise or near noise sources such as back-up buzzers or fluorescent lamps, etc. (Install at least 50cm away.)
- ② A clamp of a cable let enough length last during a camera joint and a cable clamp.
- ③ Install the cable in compliance with the positioning marks and tighten a ring by hand to a position of “-” mark.
- ④ Comply with the specified dimensions (dia.30) when drilling holes in the chassis.
- ⑤ Lay the cable within the vehicle as much as possible and keep it separate from high heat sources or moving parts.
- ⑥ When laying the cable near metallic edges, high heat sources or rotating parts, use commercially available corrugated tubes, grommets or electrical tape to protect the cable.
- ⑦ When drawing the cable into the passenger compartment use the chassis wiper harness service hole, etc.
- ⑧ This is a custom fabricated cable so never attempt to cut or twist it. Take care to avoid excessive bending. (It has minimum bend radius of R25 and minimum bend angle of 90°)

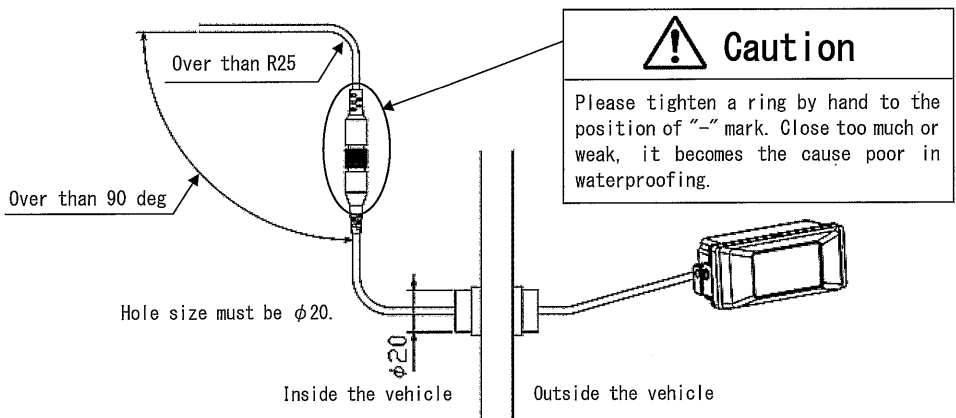

(4) Adjust the camera installation angle

- ① Adjust the camera installation angle by using the monitor screen.
- ② Secure the camera and cable by fully tightening the three screws (M4×12 : 2pcs & M3×6 : 1pc) that were only made finger-tight previously.

6. USAGE

(1) Operating the camera

- ① Put the transmission in Reverse gear and the monitor picture appears.
(When a camera is connected to camera 1 of a monitor and a reverse gear trigger of a monitor original cable is connected to Reverse gear.)
- ② The picture appears on the monitor when the monitor is on state and a camera is selected.

(2) Switching between the normal and the mirror monitor images

The monitor image can be switched between the normal and the mirror images by setting of a reshuffling switch on the camera's rear panel.

- ① Using the mirror image for viewing (monitoring of the rear)
The camera was preset to the mirror image ("M" indication point) status prior to shipment and therefore can be used as is for checking the rear.
- ② Using the normal image for viewing (monitoring of the front)
Insert a minus screw driver (blade : 5.5mm or 6.0mm) in a ditch of a reshuffling switch and please pass a reshuffling switch to a "T" indication point.

Mirror image (status when shipped)

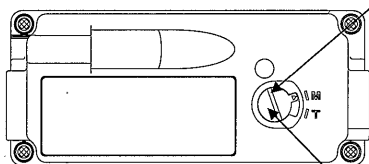

M indication point setting

Ditch

Normal image

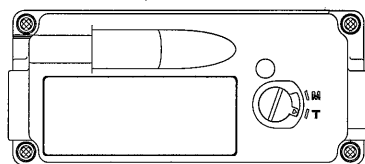

T indication point setting

Reshuffling switch

※Finishing completely
turning Reshuffling switch

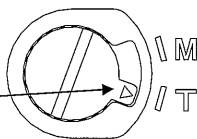

Reshuffling switch expansion

7. If I think of break down?

Before you order service, please check the following "check items". When there is an abnormality, after you take off the original cable, please order service.

Abnormality	Check items	Check
The monitor LED doesn't shine.	Isn't the monitor original cable cut or come off?	
	Isn't the fuse of the monitor original cable cut?	
The display shines, but no image appears.	Doesn't the camera cable come off?	
	Doesn't shut the camera front out with paper etc?	
The image doesn't vivid.	Isn't the front glass of a camera stained?	
	When you input a reverse gear, does backlight turn on both right and left?	
The monitor switch doesn't work. (The picture doesn't switch.)	Doesn't the monitor detect a trigger?	
	Doesn't a trigger touch DC12V/24V ACC power supply or vehicle ground?	

8. SPECIFICATIONS

(1) Image device	1/3 inch, interline transfer	L
(2) Active pixels	510 (H) x 492 (V)	
(3) Scan mode	2:1 interlace	
(4) Scanning frequency	Horizontal: 15.734kHz, Vertical: 59.94Hz	
(5) Sync	Internal	
(6) Video output	VBS : 1.0Vp-p / 75ohm (NTSC)	
(7) Resolution	Horizontal: more than 320 TV lines Vertical: more than 350 TV lines	
(8) Signal to noise ratio	More than 48dB	
(9) Illumination range	0.5lx to 100,000lx	
(10) Iris control	Electronic shutter (1/60s to 1/100,000s)	
(11) Lens (F, f)	F = 2.0, f = 2.0mm	
Field of View	Horizontal: approx. 125deg, Vertical: approx. 100deg	
(12) Image orientation	True / Mirror output (Default: Mirror)	
(13) Back light correction	Available	
(14) White balance	Automatic	
(15) Dust proof shutter	No	
(16) Power required	DC+9V (DC+8V to DC+13V from Mitsubishi monitor or power adaptor)	
(17) Power consumption	Less than 1.0W	
(18) Accessible equipment	Mitsubishi monitor (CM-7210, CM-7220, CM-7230, CM-6000) Mitsubishi power adaptor (P-0400) (Connected with cable W-30**)	
(19) Maximum cable distance	35m	
(20) Environments		
Temperature	-15°C to +50°C	
Waterproof level	JIS D 0203 (Corresponds to 14.7MPa high pressure wash jet)	
Vibration rating	JIS D 1601 (150m/s ² , 5Hz to 200Hz)	
Impact rating	JIS R 3206 (Front glass)	
(21) External dimensions	92 (W) x 40 (H) x 40.7 (D) mm (Main unit only)	
(22) Weight	approx. 180g (Main unit only)	
(23) Paint colour	Medium metallic gray	
(24) Enclosure material	Aluminium	
(25) Accessories	Installation fitting : 1pc Screw set for mounting : 1set Installation manual : 1pc	